

Technical Data Sheet

10FT Container Transport Module

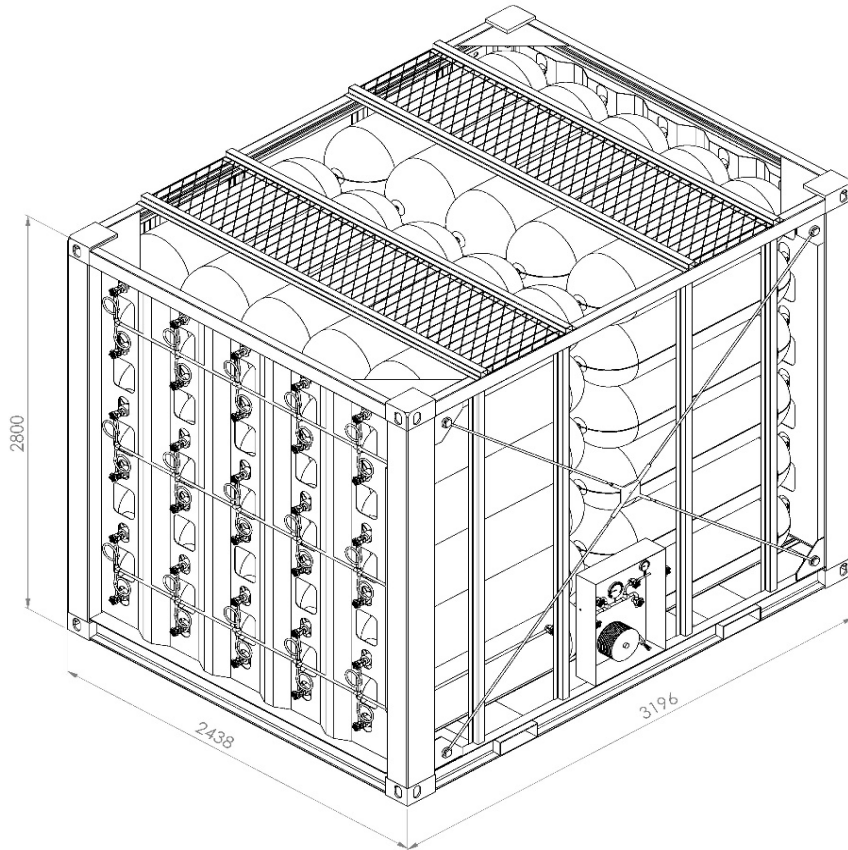

| 10FT Container Transport Module | | |
|--|---------|--------------------|
| Working pressure: | 200 | (bar) |
| Operating temperature: | -45/+60 | (°C) |
| Water volume: | 9000 | (l) |
| CNG volume: | 2272* | (Sm ³) |
| CNG weight: | 1704* | (kg) |
| Number of K-Store® CNG cylinders Type 4: | 60 | (pcs) |
| Overall Dimensions | | |
| Length | 3196 | (mm) |
| Width | 2438 | (mm) |
| Height | 2800** | (mm) |
| Package weight (empty): | 4120** | (kg) |

* Theoretical values (15°C) under ideal conditions
 ** Variation possible due to manufacturing reasons



Technical Data Sheet

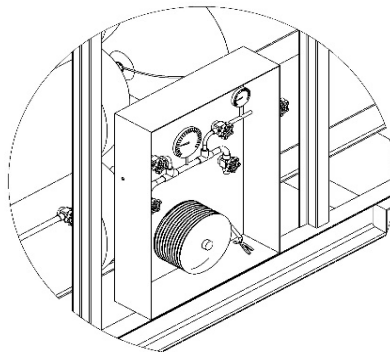

| 10FT Container Transport Module | | |
|---|------------------------------|-------|
| Housing and equipment | | |
| Container housing protection | fully galvanized | |
| Container side walls | self-extinguishing tarp | |
| Container Front and back walls | fully galvanized steel sheet | |
| Piping and fittings: | certified SS 316L / 316 Ti | |
| Control and Connection cabinet | | |
| Section shut off spindle valves | 2 | (pcs) |
| Section pressure gauge 63mm | 2 | (pcs) |
| Distribution block | 1 | (pcs) |
| Main shut-off spindle valves | 2 | (pcs) |
| Filling and discharge couplings | 2 | (pcs) |
| Venting spindle valve | 1 | (pcs) |
| Pressure gauge 100mm | 1 | (pcs) |
| Electrostatic earthing reel | 1 | (pcs) |
| Section shut off spindle valves outside cabinet | 2 | (pcs) |

* Product may differ from picture.
Picture is just for illustration

